



Features and Benefits

- Thin package: 1.55mm
- Footprint: 13.7mm x 14.1mm
- Complete VoIP hardware and software for 'Plug-n-Play' operation
- 16-bit memory-map interface to host processor. Supports major application and baseband processors
- Mobile OS Support includes: Linux[®], Windows Mobile[®], Nucleus[®] and AMX[®]
- SV1000 low-power VoIP engine with multiple power-save modes to maximize battery life
- IPSEC for network security and WPA2 for advanced WLAN security
- Active signaling for coexistence with Bluetooth radios
- Compatible with either traditional Sn-PB SMT processes or the new Pb-free

VWLAN7101 Product Brief

Embedded Module for Mobile Voice Over IP (VoIP) Applications

The VWLAN7101 is the second generation wireless voice-over-IP (VoIP) module in the SyVoice™ family of products. This highly integrated module combines the SyVoice 1000 (SV1000) VoIP processing engine with an 802.11b/g WLAN modem in a single package. The module is a complete VoIP system providing both voice and data over WLAN networks. Target applications include: cellular feature phones, wireless VoIP Phones and personal media players. The 7101 allows each of these mobile devices to operate as a VoIP phone, allowing for low-cost mobile communications.

The 7101 is a plug-n-play solution allowing quick integration into existing mobile device architectures. The 16-bit host interface is compatible with most applications processors and cellular baseband processors. The efficient SV1000 VoIP engine used in the 7101 allows this device to meet the very low power requirements for mobile devices. The VoIP engine manages all the real-time call processing in a high speed digital signal processor with minimal intervention by the host CPU. The SV1000 also has a 16-bit on chip A/D and D/A converter to maintain high voice quality.

Along with the module, SyChip provides the SyVoice™ software suite that includes all the software needed to manage a VoIP call including:

- SIP 2.0 stack
- VoCoders: G.711, G.729AB, G.726, G.723.1, G.722.2
- Call control, Audio Control, Jitter Buffer, IPSEC

The module supports data functions such as web browsing and email access. WLAN features include WPA2 security and Bluetooth coexistence.

This module comes in a Quad Flat No-Lead (QFN) package and allows direct attachment to the main Printed Circuit Board using industry standard surface mount technology for high volume production.

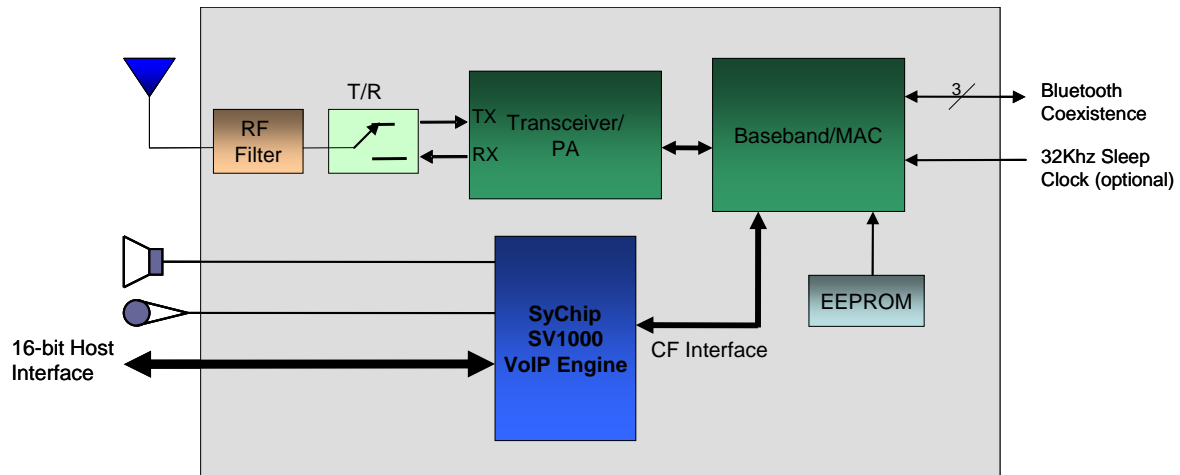

VWLAN7101 Functional Block Diagram

Specifications:

- Standards Conformance: IEEE 802.11g/b
- Frequency Range: 2.4 to 2.5 GHz
- Operational Voltage range: 3.0 to 3.6V
- RF Power: +15dBm
- Module Idle Power: 14mA
- Module Power in a Call: 151mA
- Physical Dimensions: 13.7mm x 14.1mm x 1.55mm
- Antenna Interface: PCB pad
- Host Interfaces: 16-bit Memory Map
- Max Data Rate: 11Mbps (b), 54Mbps (g)
- Security: WPA, WPA2, WEP, 802.1x
- Operating Systems Supported: Linux[®], Windows Mobile[®], Nucleus[®], AMX[®]

Visit our website: www.sychip.com

Corporate Headquarters
Parkway Centre II
2805 North Dallas Parkway, Suite 400
Plano, TX 75093 U. S. A.
Tel: (1) 972-202-8888 • Fax: (1) 972-633-0327