



Features and Benefits

- Thin package: 1.3mm typ, 1.4mm max.
- Small footprint: 8.2mm x 8.4mm
- Multiple power-save modes to maximize battery life
- Advanced Security
- Bluetooth active signaling interface for optimum packet efficiency
- QoS Packet prioritization for time sensitive payload
- OS Support for Windows Mobile, Linux
- WLAN SDIO / SPI Host Interfaces

WLAN Product Brief LBWA18HEPZ WLAN 802.11b/g module

The LBWA18HEPZ is an IEEE 802.11b/g wireless LAN module requiring just 64 square millimeters of host PCB area.

Integrated within the module are a host of active and passive components resulting in a single simple package for the customer. On module components include the WLAN chip, EEPROM, LDO regulator, driver and power amplifier, crystal, balun, and SPDT switch,

The feature set for WLAN includes IEEE 802.11i security, Quality of Service (QoS) traffic prioritization for VoIP and multimedia applications, an ultra low power sleep mode. An internal Bluetooth signaling interface along with AFH is utilized for enhanced co-existence for the two radios who share the same 2.4 GHz spectrum.

This module is targeted to consumer electronics where high integration, proven coexistence, and fast design cycles are highly valued.

The module integrates the latest silicon technology for mobile client Wireless LAN offering the best feature set while minimizing space and power consumption.

This module utilizes a QFN package and allows direct attachment to the main Printed Circuit board utilizing industry standard surface mount technology processing for high volume production.

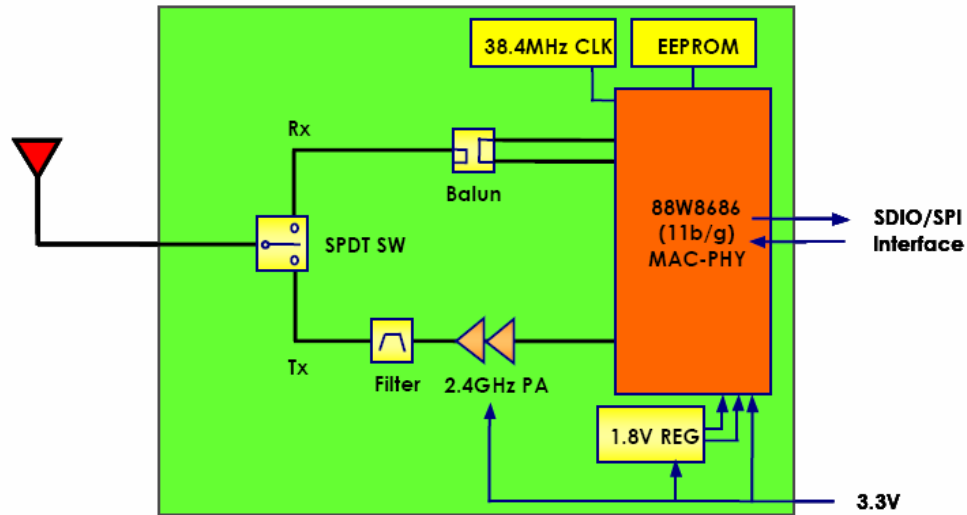

LBWA18HEPZ Block Diagram

Specifications:

- Standards Conformance: 802.11b/g WLAN
- Frequency Range: 2.4 to 2.5 GHz
- Operational Voltage range: 3.3Vdc
- WLAN Host Interface: 1.8 or 3.3vdc
- WLAN RF Power: +15dBm 54 to 1 Mbps
- Receiver sensitivity: -70dBm typ 54Mbps, -91dBm typ 11Mbps
- Power down current: 180 uA
- Receive DC Current: 175 mA
- Transmit DC Current: 300 mA
- Physical Dimensions: 8.2mm x 8.4mm x 1.3mm
- RF Interfaces: PCB pad
- WLAN Host Interfaces: SDIO, SPI

Visit our website: www.sychip.com

Corporate Headquarters
Parkway Centre II
2805 North Dallas Parkway, Suite 400
Plano, TX 75093 U. S. A.
Tel: (1) 972-202-8888 • Fax: (1) 972-633-0327